

# Scintillation Products

## Technical Note



### NEUTRON DETECTION FOR PORTAL MONITORS PERFORMANCE EVALUATION

## INTRODUCTION –

Decreasing availability of  $^3\text{He}$  and increasing demand for neutron detectors for security and scientific applications has motivated development of alternatives. Saint-Gobain Crystals has configured the well established combination of scintillation screens with wavelength shifting fibers to meet this need. The scintillation screens incorporate  $^6\text{LiF}$  &  $\text{ZnS(Ag)}$  powders mixed together in a binder and cast in a thin sheet. Neutrons are captured by the  $^6\text{Li}$  and the reaction products excite emission from the  $\text{ZnS(Ag)}$  scintillator which in turn is absorbed in an adjacent ribbon of wavelength shifting fiber. The emission induced is transmitted to the end of the fiber where it is read-out by a photomultiplier tube (PMT). The screen responds differently to gamma and neutron excitations so that pulse shape analysis of the signal helps distinguish gamma excited emission from neutron events. [\*Ref: LA-UR-99-4983C1 (1999), LA-UR-00-3004 (2000), LA-UR-01-3848 (2001)] This base technology is quite flexible and may be applied in a variety of active areas and number of layers, with PMTs at one or both ends. When sensitivity to fast neutrons is desired the detector system can be configured with an appropriate moderator.

The *NeuPort™ 2500* embodies this technology and is configured for application in Radiation Portal Monitors (RPMs). The “2500” designation is derived from its minimum neutron sensitivity, 2.5 cps/ng of moderated  $^{252}\text{Cf}$  at 2 meters. This efficiency and the module’s overall size make it appropriate for use in systems typically served by one 70” long  $^3\text{He}$  proportional counter. This report describes the *NeuPort 2500* with application to RPMs in mind, both for design and performance. The reader should keep in mind that the underlying technology can be reconfigured for other geometric or application constraints and the calibration and test can similarly be optimized for these other uses.

## NeuPort™ 2500 – System Overview

Multiple layers of scintillating screen and wavelength shifting fibers are configured in a moderator box together with proprietary pulse analyzing electronics. Neutron induced events result in an TTL pulse output; gamma events are ignored. The TTL output circuitry is capable of driving a 50 Ohm load at a distance of over 50 feet. The system is gain stabilized so that performance attributes are retained from at least -30 °C to +55 °C. The system operates from a single 5V power supply (User supplied) with a current draw of up to 1A. The assembly weighs 120 lbs and is equipped with grips at both ends for easy handling. The neutron sensitive portion of the detector is 6.5”x50” centered in the long dimension of the moderator and offset by 2.25 inches in the short dimension as shown in Figure 1.

The NeuPort 2500 is designed to meet or exceed the requirements listed in “Neutron Detector Gamma Insensitivity Criteria” report PNNL-18903 and repeated in “Alternative Neutron Detection Testing Summary” report PNNL-19311 and “Alternative Neutron Detector Technologies for Homeland Security” report PNNL-18471. Neutron detection requirements are given in terms of efficiency, gamma rejection and GARRn. The first report also references ANSI requirements for mechanical and environmental ruggedness.

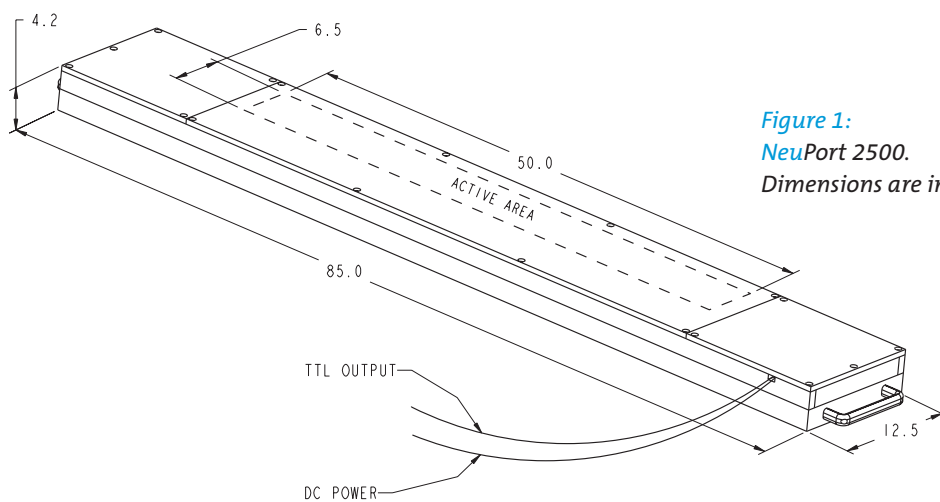

Figure 1:  
NeuPort 2500.  
Dimensions are in inches

## REQUIREMENTS & RESULTS SUMMARY

### Performance – Neutron Detection

Performance specifications for absolute neutron detection efficiency, Gamma Rejection Ratio (GRR) and Gamma Absolute Rejection Ratio in the presence of neutrons (GARRn) are shown in Table 1.1 together with a summary of results. Test methods and results are detailed later herein.

Specification	Guaranteed Performance	Typical Performance **
Efficiency	$\geq 2.5$ cps/ng*	2.65 cps/ng*
Gamma Rejection	$< 1 \times 10^{-6}$ @ 10mR/hr $^{60}\text{Co}$	$1 \times 10^{-7}$ @ 10mR/hr $^{60}\text{Co}$
GARRn	0.9 to 1.1 @ 10Mr/hr $^{60}\text{Co}$	1.08 @ 10mR/hr $^{60}\text{Co}$
* Moderated $^{252}\text{Cf}$ @ 2meters **As measured on pilot production.		

Table 1.1  
NeuPort 2500  
Performance Specifications  
& Results Summary

### Environmental & Mechanical Ruggedness

ANSI standards specify a number of environmental parameters under which performance of an RPM needs to be preserved. These conditions are listed in Table 1.2 and Table 1.3. Saint-Gobain Crystals has demonstrated the performance of the NeuPort 2500 is preserved under each of these conditions in tests that are detailed herein. One system was tested for each.

ANSI also imposes limits on the emissions radiated by an RPM as summarized in Table 1.3

Environmental Condition	Source of Requirement
Temperature (-30°C to +55°C)	ANSI N42.35-2006 & ANSI N42.38-2006
Humidity (to 93% relative)**	ANSI N42.35-2006 & ANSI N42.38-2006
Moisture & Dust**	ANSI N42.35-2006 & ANSI N42.38-2006
RF Susceptibility** (20V/m @ 80MHz to 2500MHz)	ANSI N42.35-2006
Electrostatic Discharge (up to 6kV)	ANSI N42.35-2006 & ANSI N42.38-2006
Magnetic Fields** (30A/m @ 60Hz)	ANSI N42.35-2006
Impact (up to 1J)	ANSI N42.35-2006 & ANSI N42.38-2006
Vibration (0.5g @ 10Hz to 150Hz)	ANSI N42.35-2006 & ANSI N42.38-2006
** Results rely on supplemental protection from NEMA 4 or 4X enclosure	

Table 1.2  
NeuPort 2500  
ANSI Specification  
Requirements

Requirement	Source of Requirement
Radiated Emissions	ANSI N42.35-2006 & ANSI N42.38-2006

Table 1.3  
NeuPort 2500  
Radiated Emissions

## NUCLEAR PERFORMANCE DATA

### Definitions

**Absolute neutron detection efficiency,  $|\varepsilon_n|$ ,** is the net number of neutrons detected per neutron emitted for a specified test geometry. The specification is written for irradiation with moderated  $^{252}\text{Cf}$  neutron source held at 2 meters from the center of the detector. For convenience the efficiency is often expressed as a ratio of counts per second per ng of activity, rather than neutrons detected/neutrons emitted. Equations (1).

$$|\varepsilon_n| = \frac{\text{TotalNeutronCounts} - \text{TotalBackgroundCount}}{\text{NeutronSourceEmissionRate} \times \text{Time}} \left( \frac{2314 \left( \frac{\text{neutrons}}{\text{second}} \right)}{\text{nanogram}^{252}\text{Cf}} \right) \quad (1)$$

The moderated  $^{252}\text{Cf}$  neutron source (in 5mm lead and 25mm of high density polyethylene) is located at 2 meters from the horizontal and vertical center of the front of the detector.

**Gamma Rejection Ratio, GRR,** is the intrinsic response of the neutron detector to the presence of a gamma ray field when no neutron source is present. It is the net number of indicated, but false, neutron events divided by the number of gamma photons striking the active area of the detector over the duration of the test. Equation (2).

$$GRR = \frac{\text{TotalGammaCounts} - \text{TotalBackgroundCounts}}{Q_\gamma \times BR \times \Omega \times \text{Time}} \quad (2)$$

The number of gammas incident can be calculated from the source activity and the test geometry

$Q_\gamma$  =  $^{60}\text{Co}$  Source Strength in Becquerels

BR = Branching Ratio for  $^{60}\text{Co}$  = 2

$\Omega$  = Source Detector Fractional Solid Angle, Equation 3

Where:

$$\Omega = \frac{1}{\pi} \arctan \left[ \frac{W \times L}{4 \times D \times \sqrt{\frac{W^2}{4} + \frac{L^2}{4} + D^2}} \right] \quad (3)$$

W = Detector Width=12.5 inches

L = Detector Length = 85 inches

D = Distance from  $^{60}\text{Co}$  source to detector

The PNNL specification dictates that in determining the gamma rejection ratio a  $^{60}\text{Co}$  gamma ray source should be located so the average field strength is 10mR/hr over the front face of the detector.

**Gamma absolute rejection ratio in the presence of neutrons (GARRn)** is the absolute neutron detection efficiency in the presence of neutrons and gammas,  $|\varepsilon_{\gamma n}|$ , divided by the absolute neutron detection efficiency without gammas, Equation (4).

$$GARRn = \frac{|\varepsilon_{\gamma n}|}{|\varepsilon_{\eta}|} \tag{4}$$

Where:

$$|\varepsilon_{\gamma n}| = \frac{\text{TotalCounts}(\eta + \gamma) - \text{TotalBackgroundCounts}}{\text{NeutronSourceEmmisionRate} \times \text{Time}}$$

In determining GARRn a moderated  $^{252}\text{Cf}$  neutron source (in 5mm lead and 25mm of high density polyethylene) should be located at 2 meters from the horizontal and vertical center of the front of the detector and a  $^{60}\text{Co}$  gamma ray source should be located so the average field strength is 10mR/hr over the front face of the detector.

**Test Set-up.** The required test sources and electronics have been acquired and installed permanently at Saint-Gobain Crystals for routine testing of these products. Each NeuPort 2500 system is rigorously tested for the performance requirements described.

### Observed Performance

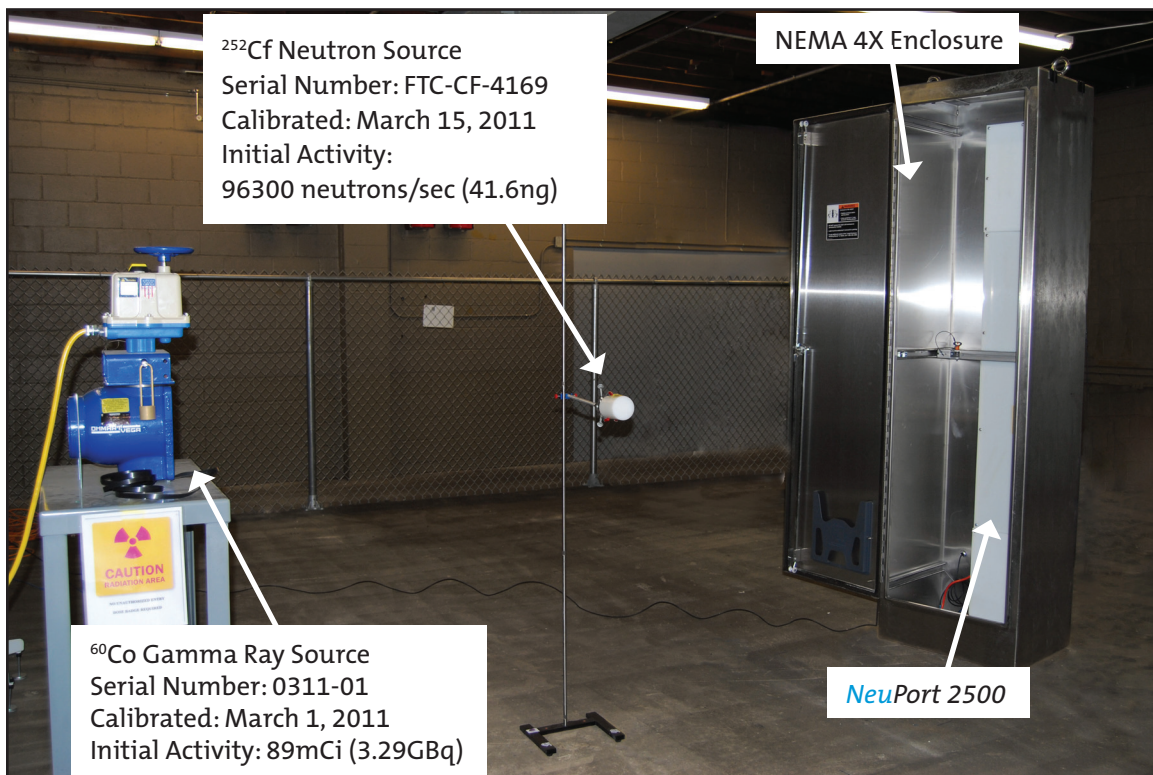

Figure 2.1:  
NeuPort 2500 Performance Test Set-Up

Requirement	Saint-Gobain Crystals Guaranteed Performance	Typical Performance
$ \varepsilon_{\eta} $	2.5 cps/ng Moderated $^{252}\text{Cf}$ @ 2meters	2.65cps/ng moderated $^{252}\text{Cf}$ @ 2 meters
GRR	$1 \times 10^{-6}$ @ 10mR/hr $^{60}\text{Co}$	$1 \times 10^{-7}$ @ 10mR/hr $^{60}\text{Co}$
GARRn	0.9 - 1.1 @ 10mR/hr $^{60}\text{Co}$	1.08 @ 10mR/hr $^{60}\text{Co}$

Table 2.1:  
NeuPort 2500  
Performance

## ENVIRONMENTAL & MECHANICAL RUGGEDNESS

For the environmental and mechanical ruggedness requirements listed by ANSI standards and referenced in the PNNL reports, a single unit was tested to qualify the design.

### Temperature

**Test Requirements** ANSI N42.35-2006, Section 7.1 requires that the Neutron Detection Module (NDM) operate over a temperature range from  $-30^{\circ}\text{C}$  to  $+55^{\circ}\text{C}$ . The neutron response, the count rate, of the NDM is collected for a series of neutron readings using a  $^{252}\text{Cf}$  neutron source. The response is determined from 10 independent readings and the mean and coefficient of variation (COV) are calculated. The COV for each mean reading shall be less than or equal to 12%. COV is defined as the ratio of standard deviation,  $\sigma$ , to the mean,  $\mu$ , i.e.  $\text{COV} = \sigma/\mu * 100\%$ . The  $^{252}\text{Cf}$  source is positioned in order to achieve a minimum of 10,000 counts at each independent reading for good count rate statistics, i.e. 1% error.

The ANSI N42.35, Section 7.1, temperature profile is shown in Figure 3.1.

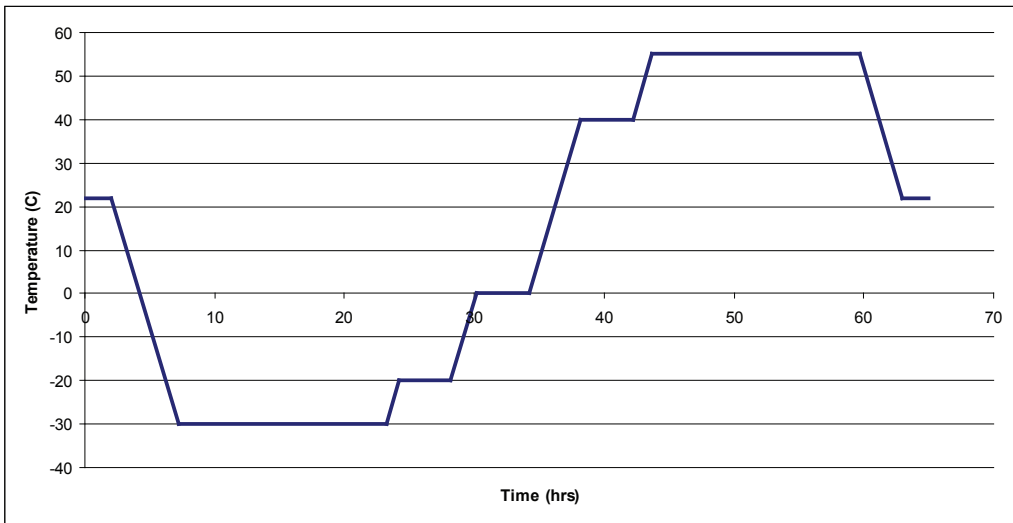

Figure 3.1:  
ANSI Temperature Profile

Results are acceptable if the mean reading obtained at each temperature test point is within  $\pm 15\%$  of the mean reading obtained at ambient room temperature. The mean baseline reading is taken at the end of the ambient room temperature stabilization period of not less than 2 hours. The NDM soaks for 16 hours at  $-30^{\circ}\text{C}$  and  $+55^{\circ}\text{C}$ ; and readings are taken after 1 hour, 7 hours and at the end of the 16 hour period. The NDM soaks for 4 hours at  $-20^{\circ}\text{C}$ ,  $0^{\circ}\text{C}$ , and  $+40^{\circ}\text{C}$ ; and readings are taken at the end of each 4 hour period. The ramp rate between each temperature is not to exceed  $10^{\circ}\text{C}/\text{hour}$ . Once the NDM is brought back to room temperature a final reading is made after a 2 hour stabilization period.

**Test Set-up.** For the duration of the temperature cycle, the NDM is installed inside a grounded NEMA 4 enclosure. A +5VDC power supply is placed inside the NEMA 4 enclosure next to the NDM, and a shielded cable is used to carry the TTL digital pulse to the counting electronics located outside the environmental chamber. See Figure 3.2.



Figure 3.2:  
Ambient Temperature Test Set-Up

**Performance.** The NeuPort 2500 meets the ambient temperature requirements set forth in ANSI N42.35-2006 as shown by these tests. The system tested registered the performance displayed and listed in Figure 3.3 and Table 3.1. The mean readings vary less than 3% from the room temperature baseline, well within the 15% specification. The coefficients of variation at each test point are under 2%, well within the 12% requirement.

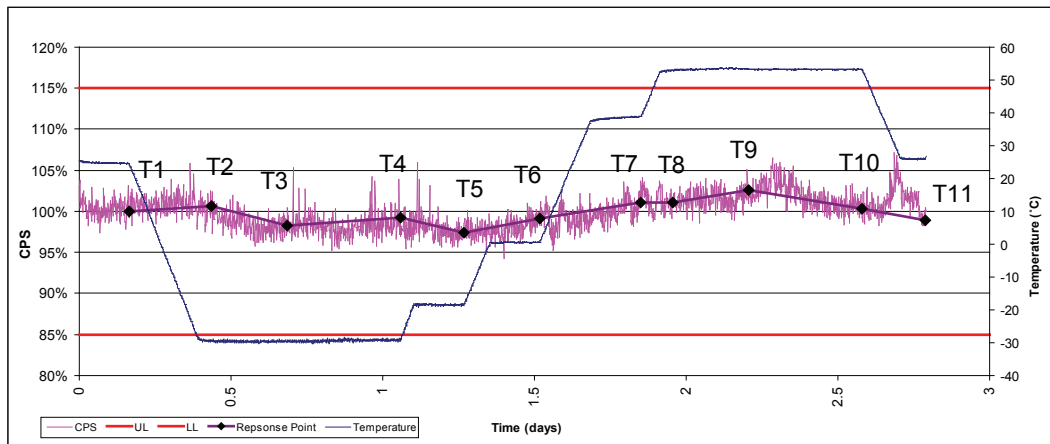

Figure 3.3:  
Relative Neutron Count Rate vs. Temperature

Response Point	$\eta$ -counts/sec (relative to baseline)	Temperature (C)	Time (hours)	COV
Base (T1)	100.0%	22	3.9	1.47%
T2	100.6%	-30	10.4	0.96%
T3	98.3%	-30	16.4	1.02%
T4	99.2%	-30	25.4	1.89%
T5	97.4%	-20	30.4	0.55%
T6	99.1%	0	36.4	0.71%
T7	101.1%	40	44.4	1.25%
T8	101.1%	55	46.9	1.05%
T9	102.6%	55	52.9	1.05%
T10	100.4%	55	61.9	0.88%
T11	99.0%	22	66.9	0.67%

Table 3.1:  
Relative Neutron Response vs. Temperature



### Radio Frequency Susceptibility

**Test Requirements.** ANSI N42.35-2006, Section 8.1 requires that the NDM shall not be affected by radio frequency (RF) fields over the frequency range of 80 MHz to 2500 MHz that is 80% amplitude modulated with a 1kHz sine wave. The RF field intensity is 20 volts per meter (V/m) when one side of the NDM is exposed.

The neutron response, count rate, of the NDM is to be collected during an automated frequency sweep at a change rate of 1% of the fundamental (previous) frequency using a <sup>252</sup>Cf neutron source. The dwell time at each frequency should be at least 3 seconds. The results are acceptable if the detector response does not deviate by more than ± 15% of the initial mean neutron reading during the RF exposure.

**Test Set-up.** The NDM is installed inside a grounded NEMA 4X enclosure. A +5VDC power supply is placed inside the NEMA 4X enclosure next to the NDM, and a shielded coax cable is used to carry the TTL digital pulse to the counting electronics located outside the RF chamber. A <sup>252</sup>Cf neutron source is placed in front of the enclosure in such a way as to not affect the RF field. See Figure 4.1.

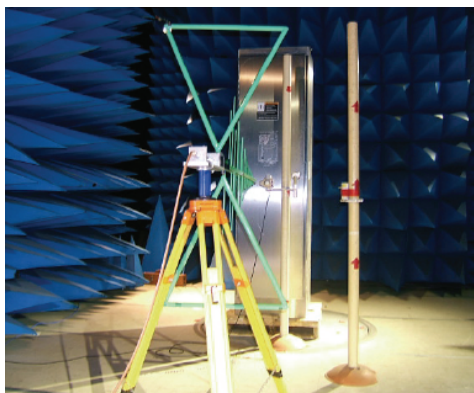

Figure 4.1:  
Radio Frequency Susceptibility Testing

Due to the frequency range and detector size, the measurements are split into three groups, each of which required dedicated RF amplifiers and antennas specific to a frequency range. The three frequency ranges are 80MHz-1GHz, 1Ghz-2Ghz, and 2Ghz-2.5Ghz. Prior to testing, the 20V/m field is verified at several locations with a calibrated RF meter. The automated frequency sweeper changed the frequency at rate of 1% of the fundamental frequency with a dwell time of 10 seconds.

**Performance** Based on the data shown Figure 4.2 and Table 4.1 the NeuPort 2500 meets the radio frequency susceptibility requirements set forth in ANSI N42.35-2006. The table shows performance before, during and after RF exposure. Changes are less than 1%, well within the 15% specification. The figure shows changes in short count time response as a function of RF frequency applied. Again response is well within the 15% limits and the greater variation is attributed to counting statistics.

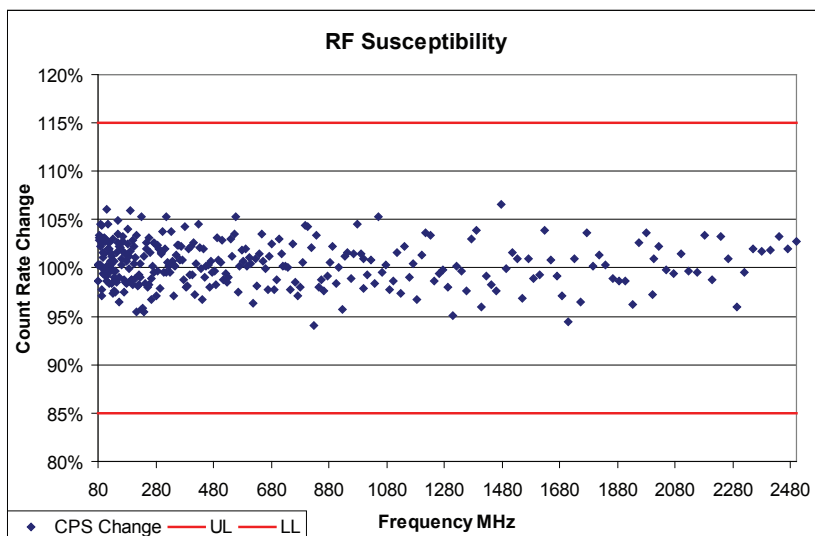

Figure 4.2:  
Neutron response to RF



Frequency Range (MHz)	$\eta$ -counts/sec (relative to baseline)		
	Baseline	During RF Exposure	After RF Exposure
80 to 1000	100.0%	100.5%	99.3%
1000 to 2000	100.0%	99.9%	100.6%
2000 to 2500	100.0%	100.8%	99.0%

*Table 4.1:  
Relative Neutron Response to RF*

### Magnetic Fields

**Test Requirements.** ANSI N42.38-2006, Section 8.5 requires that the neutron detection module shall be unaffected by Magnetic fields of 30 Amperes/meter (A/m) at 60 Hz. The test shall be performed in two orientations (0° and 90°) relative to the field lines.

The neutron response, the count rate, of the NDM is collected before, during, and after the magnetic field exposure using a <sup>252</sup>Cf neutron source. The results are acceptable if the detector response does not deviate by more than ± 15% of the initial mean neutron reading during exposure to the magnetic field.

**Test Set-up.** The NDM is installed inside a grounded NEMA 4X enclosure. A +5VDC power supply is placed inside the NEMA 4X enclosure next to the NDM, and a shielded coax cable is used to carry the TTL digital pulse to the counting electronics located outside the RF chamber. A <sup>252</sup>Cf neutron source is placed in front of the enclosure in such a way as to not affect the magnetic field.

For the 0° orientation, the field is applied around the NEMA 4X enclosure at the middle of the NDM. The 90° orientation magnetic field is applied at the back of the enclosure in order to ensure the closest proximity to the NDM. See Figures 5.1 and 5.2.

Prior to testing, the 30A/m field is verified on both orientations using a calibrated AC clamp meter.

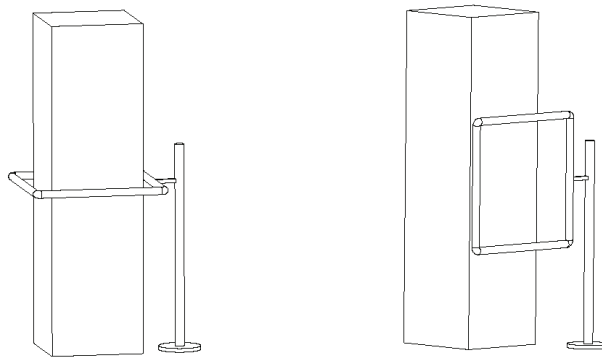

*Figure 5.1:  
Magnetic Field Coil Orientation*

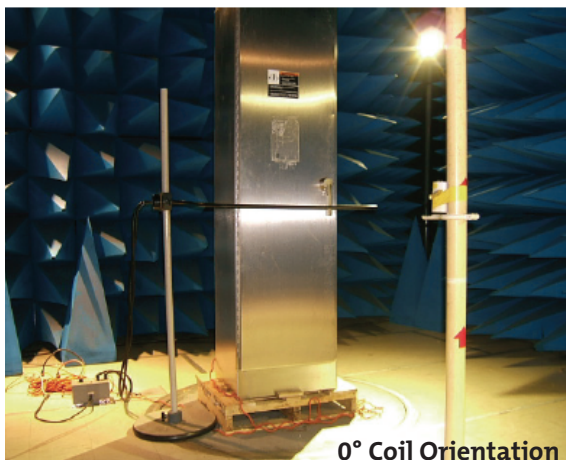

**0° Coil Orientation**



**90° Coil Orientation**

*Figure 5.2:  
Magnetic Field Testing*

**Performance** The system tested exhibited the response shown in Table 5.1. Response during and after exposure to magnetic fields changes less than 1%, well within the 15% specification. The NeuPort 2500 meets the magnetic field susceptibility requirements set forth in ANSI N42.38-2006.

Orientation	$\eta$ -counts/sec (relative to baseline)		
	Baseline	During Magnetic Field Exposure	After Magnetic Field Exposure
0°	100.0%	100.5%	100.9%
90°	100.0%	99.1%	99.2%

*Table 5.1:  
Relative Neutron Response to Magnetic Fields*

**Vibration**

**Test Requirements.** ANSI N42.35-2006, Section 9.2 requires that the NDM operates normally and that no physical changes (loose bolts, connectors, solder joints, etc.) occur when exposed to vibrations up to 0.5g over a frequency range from 10Hz to 150Hz.

The test shall consist of ten, two minute, logarithmic sweeps through the frequency range. The neutron response, count rate, of the NDM is collected using a <sup>252</sup>Cf neutron source.

Results are acceptable if the mean reading obtained at each test point is within ±15% of the mean reading obtained at baseline.

**Test Set-up.** Due to the physical size and weight of the NDM, a half NDM was tested in two orientations, see Figure 6.1. The specification calls for testing in the vertical orientation.

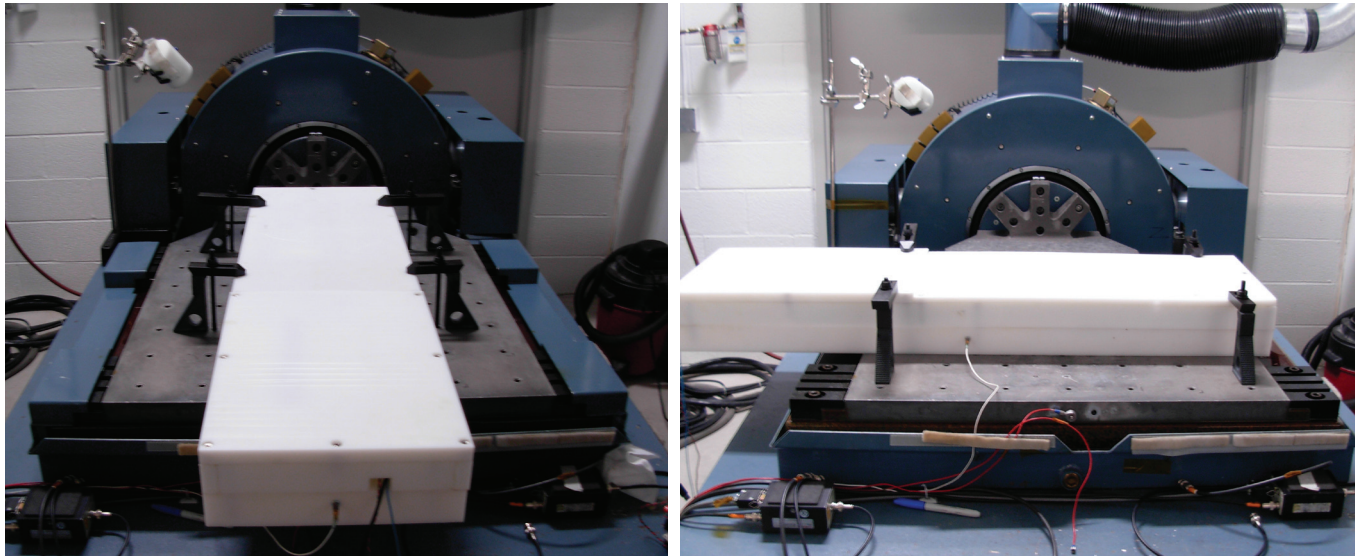

*Figure 6.1:  
Vibration Testing of Half NDM*

**Performance.** After vibration the NDM showed no physical changes. During vibration the system tested responded as shown in Figures 6.2 where we see variation in response at less than  $\pm 10\%$  vs. specification limits at  $\pm 15\%$ . The observed variation is attributable to counting statistics.

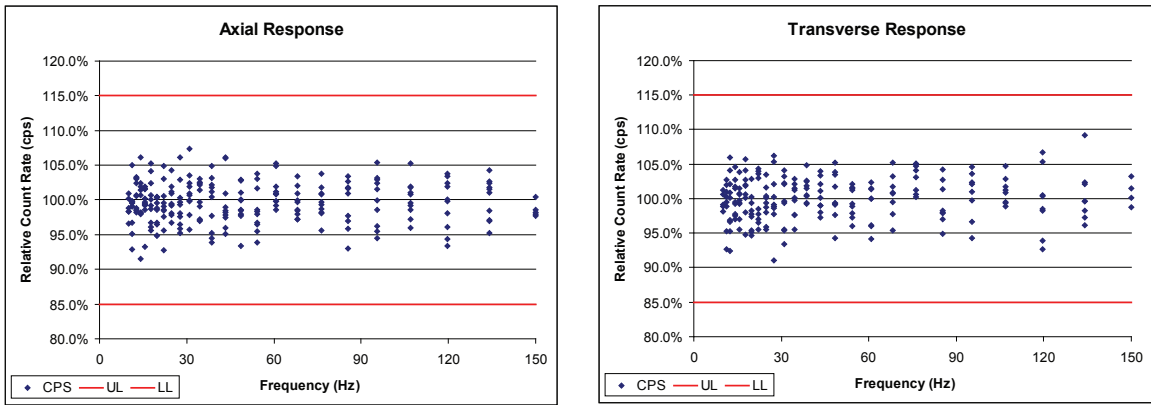

Figure 6.2:  
Relative Neutron Response to Vibrations

To further demonstrate that the NeuPort 2500 is designed to meet the vibration requirement set forth in ANSI N42.35-2006 the vibration test was repeated at 3.5g with similar results. During field use, the NDM will need to be securely mounted within an RPM system in order to successfully meet this requirement. Saint-Gobain Crystals recommends working with us to define an acceptable mounting arrangement.

**Shock/Impact**

**Test Requirements.** ANSI N42.35-2006, Section 9.1 requires that the NDM be unaffected by impacts at energies up to 1.0J. The neutron response, count rate, of the NDM is collected before and after exposure to the impact using a <sup>252</sup>Cf neutron source. Results are acceptable if the mean reading obtained post impact is within  $\pm 15\%$  of the mean baseline reading.

**Test Set-up.** The NDM is exposed to three 1.0J impacts with a calibrated spring hammer (PTL model number: F22.50, serial number: CL022450) at the locations shown in Figure 7.1 and Figure 7.2.

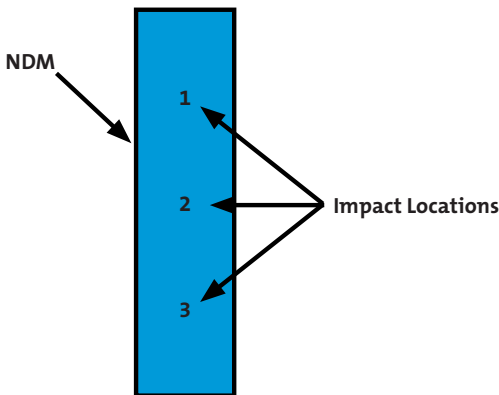

Figure 7.1:  
NDM Impact Locations

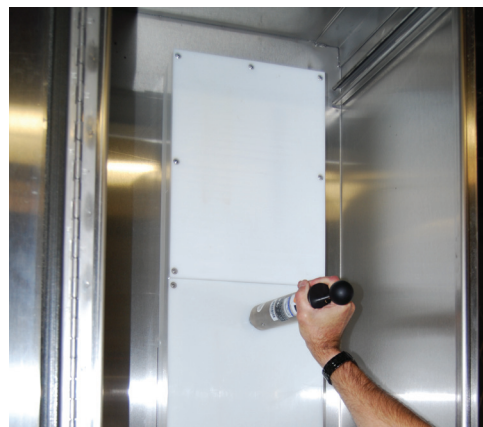

Figure 7.2:  
Impact Testing

**Performance.** As summarized in Table 7.1, no significant change in response is seen after impact and the NeuPort 2500 meets the impact requirement set forth in ANSI N42.35-2006.

$\eta$ -counts/sec (relative to baseline)	
Baseline	After Impact
100.0%	99.6%

Table 7.1:  
Relative Neutron Response to Impact

### Electrostatic Discharge

**Test Requirements.** ANSI N42.35-2006, Section 8.5 requires that the NDM be unaffected by exposure to electrostatic discharge (ESD) of up to 6kV using the contact discharge technique. The neutron response, the count rate, of the NDM is collected before and after exposure to ESD using a <sup>252</sup>Cf neutron source. Results are acceptable if the mean reading obtained post ESD is within  $\pm 15\%$  of the mean baseline reading.

**Test Set-up.** Due to the high impedance of the High Density Polyethylene moderator, several screws, as shown in Figure 8.1, were grounded in order to expose the NDM to ten discharges with a calibrated ESD simulator gun (Schaffner model number: NSG438, serial number: 1149), with a 1 second recovery time between each discharge. The discharge voltage is incrementally applied at 2kV, 4kV, and 6kV.

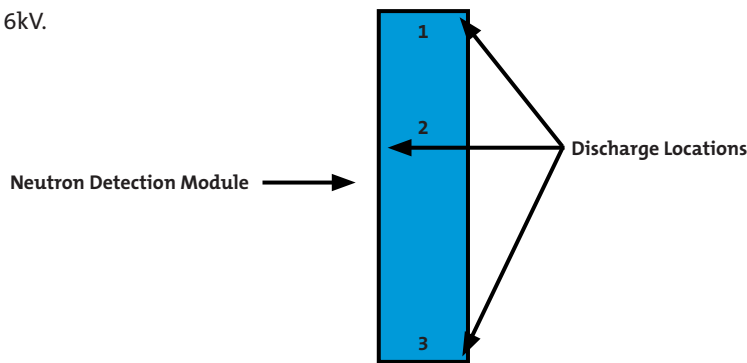

Figure 8.1:  
NDM Discharge Locations

**Performance.** Based on the data shown in Table 8.1, the NeuPort 2500 meets the ESD requirement set forth in ANSI N42.35-2006.

$\eta$ -counts/sec (relative to baseline)	
Baseline	After ESD exposure
100.0%	99.1%

Table 8.1:  
Relative Neutron Response to ESD

### Radiated Emissions

**Test Requirements.** ANSI N42.35-2006, Section 8.2 requires that the emission limits for the neutron detection module shall be less than the values shown in Table 9.1.

Frequency (MHz)	Field Strength	
	( $\mu$ V/m)	(dB $\mu$ V/m)
30 to 88	100	40
88 to 216	150	44
216 to 960	200	46
>960	500	54

Table 9.1:  
Emission Limits

The RF antenna is positioned 3 meters from the assembly and a scanning bandwidth of 50 kHz is used for the measurements. An emission spectrum is collected with the power on and off (background).

**Test Set-up.** The NDM is installed inside a grounded NEMA 4X enclosure. A +5VDC power supply is placed inside the NEMA 4X enclosure next to the NDM, and a shielded coaxial cable is used to carry the TTL digital pulse to the counting electronics located outside the RF shielded chamber.

In order to determine the location with the highest emission level, the NEMA 4X enclosure is positioned on a 360° rotating platform. At a distance of 3m, the RF antenna is mounted to a platform that allows it to rotate between 0° and 90° as well as travel vertically to scan the height of the system. See Figures 9.1 and 9.2.

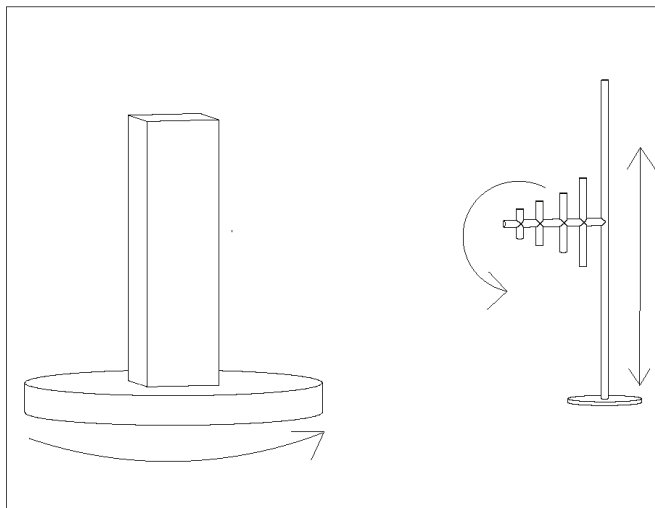

*Figure 9.1:  
Radiated Emission Test Set-up*



*Figure 9.2:  
Radiated Emission Testing*



**Performance.** The data shown in Figure 9.3 and 9.4 show that emissions radiated from the NeuPort 2500 are well below the specification line (also indicated in the figure in red) so that the module meets the radiated emissions requirement set forth in ANSI N42.35-2006. Figure 9.3 is the spectrum with the detector module present but turned off. In Figure 9.4 the module is energized.

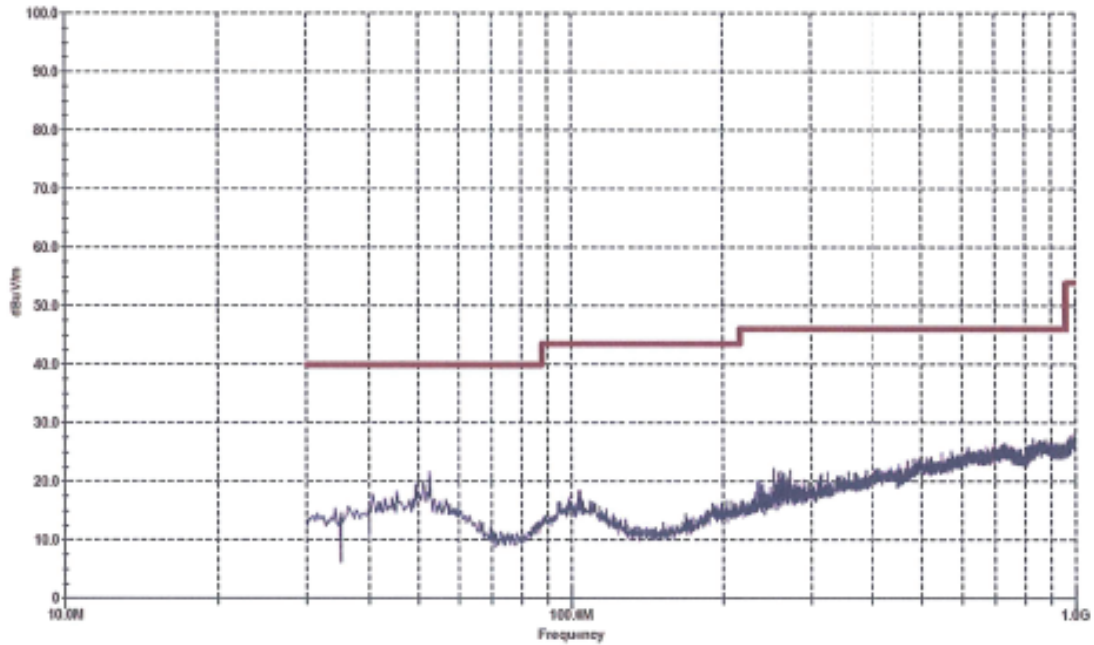

Figure 9.3:  
Background Radiated Emissions Spectrum

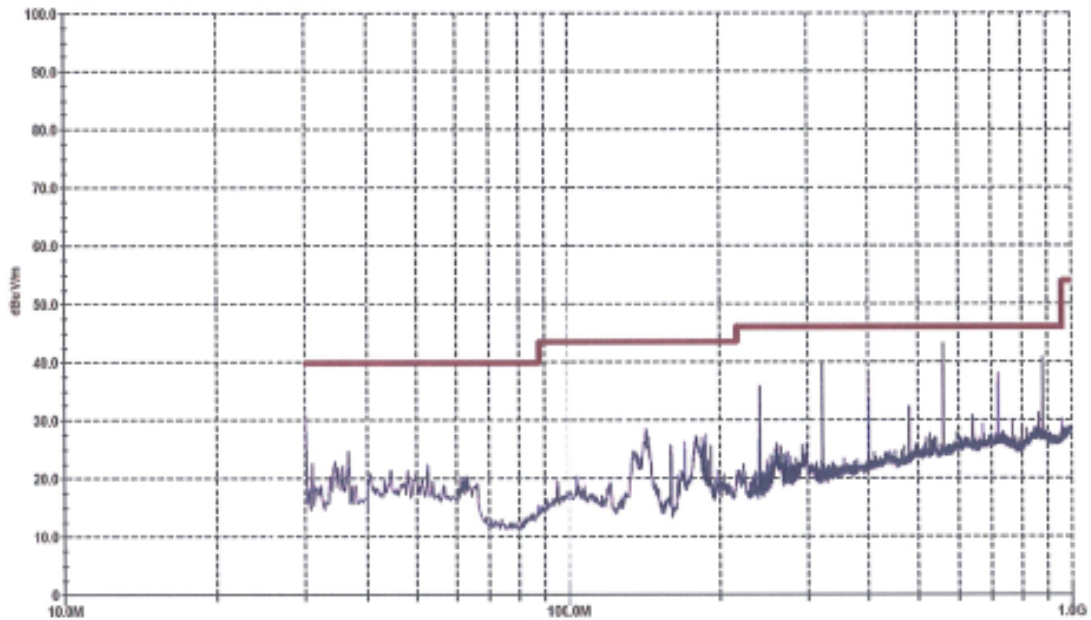

Figure 9.4:  
Radiated Emission Spectrum from NeuPort 2500

SYMBOLS, ACRONYMS & ABBREVIATIONS

**A**

A Ampere  
ANSI American National Standards Institute  
AC Alternating Current

**B**

BR Branching Ratio

**C**

C Centigrade  
<sup>252</sup>Cf Californium-252  
<sup>60</sup>Co Cobalt-60  
COV Coefficient of Variation  
CPS Counts per Second

**D**

D Distance from <sup>60</sup>Co Source to Detector  
dB Decibel  
° Degree (Angle or Temperature)

**E**

$|\epsilon_n|$  Absolute Neutron Detection Efficiency  
 $|\epsilon_{\gamma n}|$  Absolute Neutron Detection Efficiency in the Presence of Neutrons and Gammas  
ESD Electrostatic Discharge

**F**

**G**

g Acceleration, Relative to Gravity  
GARRn Gamma Absolute Rejection Ratio for Neutrons  
GBq Giga Becquerels  
GRR Gamma Rejection Ratio  
GHz Gigahertz

**H**

<sup>3</sup>He Helium-3  
HDPE High Density Polyethylene  
hr Hour  
Hz Hertz

**I**

**J**

J Joule

**K**

kHz Kilohertz  
kV Kilovolts

**L**

L Detector Length  
<sup>6</sup>LiF Lithium-6 Flouride  
lbs. Pounds  
LL Lower Limit

**M**

$\mu$  Mean (Average) or Micro  
MC Milli Curies  
MHz Megahertz  
m Meter  
mm Millimeter  
mR Millirem

**N**

NEMA National Electrical Manufacturer's Association  
ng Nanogram  
 $\eta$  Neutron  
NDM Neutron Detection Module

**O**

$\Omega$  Ohm or Source Detector Fractional Solid Angle

**P**

PNNL Pacific Northwest Laboratory  
PMT Photomultiplier tube

**Q**

$Q_\gamma$  <sup>60</sup>Co Source Strength in Becquerels

**R**

RPM Radiation Portal Monitor  
RF Radio Frequency

**S**

SGC Saint-Gobain Crystals  
sec Seconds  
 $\sigma$  Standard Deviation

**T**

TTL Transistor-Transistor Logic

**U**

UL Upper Limit

**V**

V Volts  
V/m Volt per meter  
VDC Volts (Direct Current)

**W**

W Watt or Detector Width

**X**

**Y**

**Z**

ZnS(Ag) Zinc Sulfide (doped Ag)





**Compiled and Edited by Lance Wilson, Artan Duraj & Mike Kusner.  
Originally prepared for distribution by Saint-Gobain Crystals at IEEE NSS/MIC Valencia, Spain,  
October 2011.**

***Saint-Gobain Crystals, Scintillation Products***

*In U.S.A.: +1 440 834 5600*

*In France: 33 (1) 64 45 10 10*

*In Japan: 81 (0) 3 3263 0559*

*In China: 86 (0) 10 6461-0260*

*In India: 91 80 42468989*

*[www.crystals.saint-gobain.com](http://www.crystals.saint-gobain.com)*

*SGC : Original Publication Date: 1011*

*Manufacturer reserves the right to alter specifications. ©2011 Saint-Gobain Ceramics & Plastics, Inc. All rights reserved.*